



HP3G SERIES

Swash-plate Type Axial Piston Variable Displacement Pump

HP3G series variable axial piston pump with swashplate design for hydrostatic drives in closed circuit, high pressure, high speed, high reliability, low noise, can be applied in engineering machinery and mobile machinery.

Applied in medium pressure closed circuit

Size	46
Rated pressure	345bar
Max. pressure	385bar

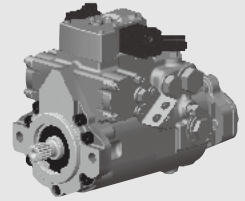

Contents

Technical Data	02
Type introduction	03-05
Pump principle	06
Connector	06
Electrical displacement control (EDC)	
· EDC Principle	07
· Pump displacement—control current	07
· EDC Response time	07
Installation size	
· HP3G46 Installation size	08
· Port details	09
· HP3G46 Mounting Flange	10
· HP3G46 Input Shaft type	10

Features

- Variable axial piston pump of swashplate design for hydrostatic drives in closed circuit.
- The flow is proportional to the drive speed and displacement. The flow increases as the angle of the swashplate is adjusted from zero to its maximum value.
- Flow direction changes smoothly when the swashplate is moved through the neutral position.
- Two pressure-relief valves are provided on the high pressure ports to protect the hydrostatic transmission (pump and motor) from overload.
- The integrated charge pump can provide system replenishing and cooling fluid flow.
- High reliability, long working lifetime
- Compact structure, high power density.

Technical data

Size		46
Displacement (cc/rev)		45.9
Speed	Rated (rpm)	4000
	Max. (rpm)	4100
	Min. (rpm)	500
Pressure	Rated (bar) (relative to Charge pressure)	345
	Max. (bar) (relative to Charge pressure)	385
	Minimum low loop pressure(bar) (relative to Charge pump)	10
Charge pressure (relative to Charge pump)	Min. (bar)	6
	Max. (bar)	31
Control Pressure (relative to Charge pump)	Min. (bar)(EDC control)(bar)	21.5
Charge pump	Rated (bar)	1.7
	Max. (bar)	5.2
Casting pressure (Absolute pressure)	Rated (bar)	0.8
	Max. (bar)	6
Oil viscosity (mm ² /s)		10~1000, Best range: 16~36
Oil Temperature (°C)		-20~95
Oil Cleanliness		ISO 4406 Class 18/13 or higher
Weight (w/o auxiliary flange) (Kg)		33

Type introduction

HP3G	46	A	R	A2	N	F	S2	B1	K28	K28	B	P	J	PN	
①	②	③	④	⑤	⑥	⑦	⑧	⑨	⑩	⑪	⑫	⑬	⑭	⑮	⑯

Product series

①	Variable piston pump of swashplate in closed circuit	HP3G
---	--	------

Displacement

②	Displacement cc/rev	46
---	---------------------	----

Product version

③	Series code	A
---	-------------	---

Rotation

④	Right hand (clockwise)	R
	Left hand (counter clockwise)	L

Control

⑤	High Current Electric Displacement Control (HC EDC), oil filled, Deutsch DT04-2P, Voltage 12V DC. Control Range: 350mA~950mA	A2
---	--	----

Displacement Limiters

⑥	Without Displacement Limiters, 46cc/rev	N
	With mechanical stroke limiter, externally adjustable	M

Mounting flange

⑦	ISO 3019-1, SAE B-2 hole (101-2)	F
---	----------------------------------	---

Input shaft

⑧	SAE J744-22-4 13T 16/32DP	S1
	SAE J744-25-4 15T 16/32DP	S2

Type introduction

Through drive option

	No through drive	NN
	SAE A 82-2 SAE J744-16-4 9T 16/32DP	A1
⑨	SAE A 82-2 SAE J744-19-4 11T 16/32DP	A2
	SAE B 101-2 SAE J744-22-4 13T 16/32DP	B1
	SAE B 101-2 SAE J744-25-4 15T 16/32DP	B2

Setting pressure of the relief valve

⑩—Overpressure Protection Type and Setting Side "A"

⑪—Overpressure Protection Type and Setting Side "B"

⑩	High pressure relief valve setting	140 bar	K14
		175 bar	K17
		190 bar	K19
		210 bar	K21
		230 bar	K23
⑪	(differential pressure: relative to Charge pressure)	250 bar	K25
		280 bar	K28
		320 bar	K32
		345 bar	K35

Please contact us for configurations or pressures not shown in above form.

Charge pump

⑫	With charge pump, 13.9 cc/rev	B
	Without charge pump, need external charge	N

Filtration Options

⑬	Suction, with charge pump	L
	Remote pressure, with charge pump	P

Type introduction

Charge pressure

⑭	19.5 bar	B
	21.5 bar	J
	25 bar	S

Control orifice

⑮	Control orifice of Servo A&B ϕ 0.9mm	PN
	Control orifice of Servo A&B ϕ 1.4mm	SN
	Without control orifice	NN

Paint and Nameplate

⑯	Black paint and Hengli nameplate	Blank
---	----------------------------------	-------

Pump principle

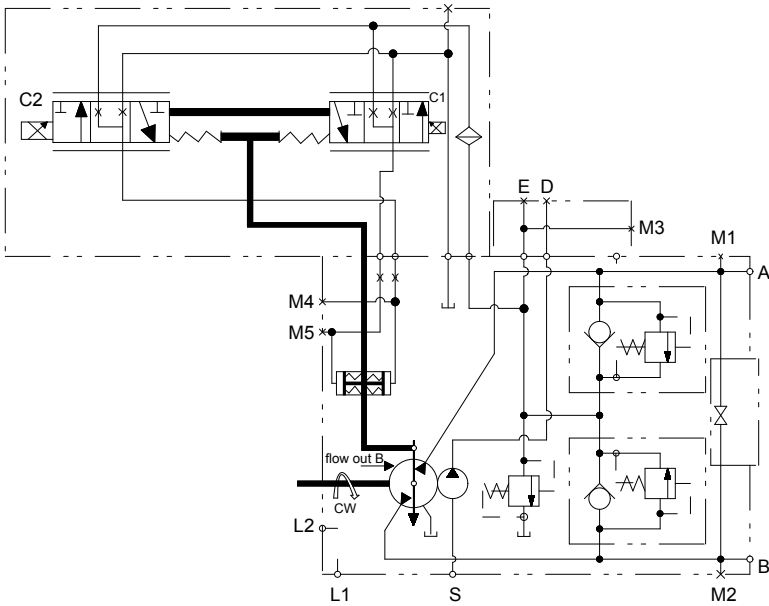

Input shaft rotation	CW		CCW	
Energized coil	C2	C1	C2	C1
Oil port A	In	Out	Out	In
Oil port B	Out	In	In	Out
Servo pressure acting oil port	M5	M4	M5	M4

Connector:

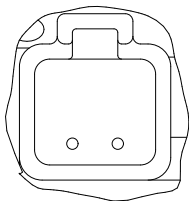

Deutsch DT04-2P
 Voltage: 12V
 V View

Refer to pump installation drawing for port locations.

Electrical displacement control (EDC)

The High Current Electrical Displacement Control (HC EDC) consists of a pair of proportional solenoids on each side of a three-position, four-way porting spool. The proportional solenoid applies a force input to the spool, which ports hydraulic pressure to either side of a double acting servo piston. Differential pressure across the servo piston rotates the swashplate, changing the pump's displacement from full displacement in one direction to full displacement in the opposite direction.

A serviceable 125 µm screen is located in the supply line immediately before the control porting spool.

Features:

- Precision parts provide repeatable accurate displacement settings with a given input signal.
- Both ends of the double acting servo piston are drained to case when input signal current is not present. The servo piston is coupled to a spring centering mechanism.

Benefits:

- Simple, low-cost design.
- Pump will return to neutral after prime mover shuts down.
- Pump will return to neutral if external electrical input signal fails or if there is a loss of charge pressure

• Pump displacement – control current

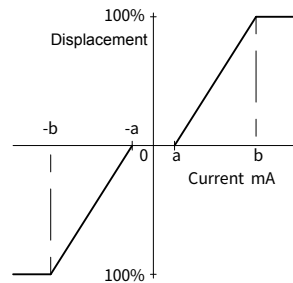

• EDC Response time

Orifice diameter* mm [in]	Average response time [seconds]	
	Acceleration	Deceleration
1.2 [0.046]	2.0	1.6
None	0.9	1.0

*Contact Hengli for special orifice combinations.

Installation size

HP3G46 installation size

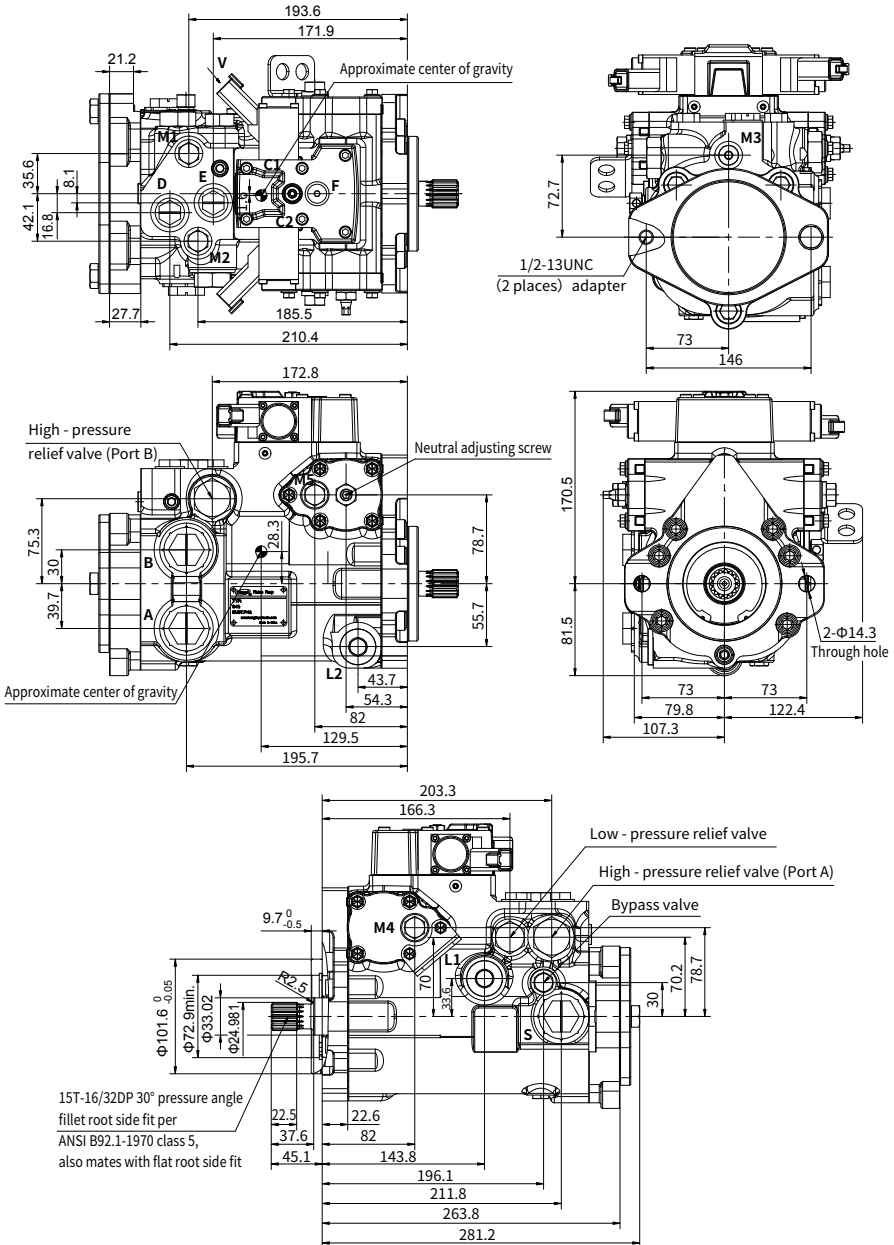

Installation size

• Port details

	Port Name	Port Size and Description	Tightening Torque(N.m)
S	Charge Pressure Inlet	SAE J1926/1 (1 5/16-12UN-2B)	134
A, B	Working Port	SAE J1926/1 (1 5/16-12UN-2B)	134
L1, L2	Case Drain Port	SAE J1926/1 (1 1/16-12UN-2B)	101
M1, M2	Port "A" and "B" Gage Port	SAE J1926/1 (9/16-18UNF-2B)	25
M3	Gauge Port Of Charge Pump	SAE J1926/1(9/16-18UNF-2B)	25
M4, M5	Servo Gage Port	SAE J1926/1 (9/16-18UNF-2B)	25
D	Charge filtration port D (To remote filter ISO 11926-1 7/8-14 Charge filtration port D Charge gauge port for remote filtration with charge pump option)	SAE J1926/1 (7/8-14UNF-2B)	73
E	Charge filtration port E (From remote filter Charge gauge port for remote filtration with or w/o charge pump option)	SAE J1926/1 (7/8-14UNF-2B)	73
F	Air Bleed Port	SAE J1926/1(7/16-20UNF-2B)	15

Installation size

HP3G46 Mounting Flange

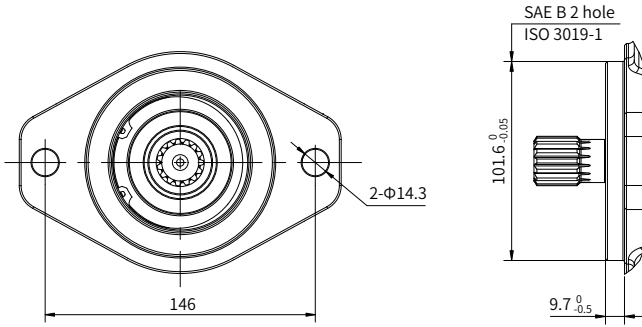

HP3G46 Input Shaft type

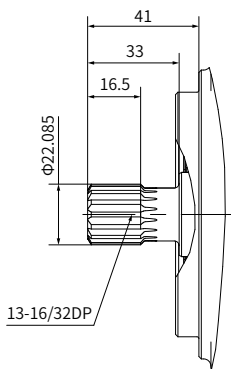

"S1" type spline shaft

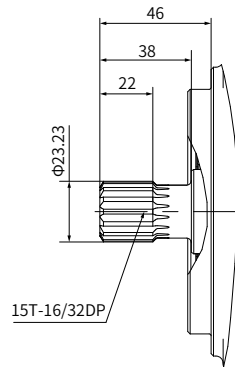

"S2" type spline shaft